

Custom Hard- Wired Social Security Systems



These are the diagrams and operation explanations for four available Social Security Office Calling Systems.

Model numbers, descriptions and prices are listed below.

[Back To Products](#) [Back to Special Systems](#)

CLAIM REP INTERVIEW CALLING SYSTEM - CRI- 10 OPERATION:

Receptionist signals Claim Rep by number when a claimant has arrived for appointment. Claim Rep switches off light when meeting claimant at reception area.

CLAIM REP INTERVIEW CALLING SYSTEM:

#H10 Number Panel



#CH100 Chime



#10KR Switch Panel

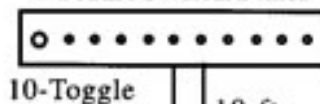

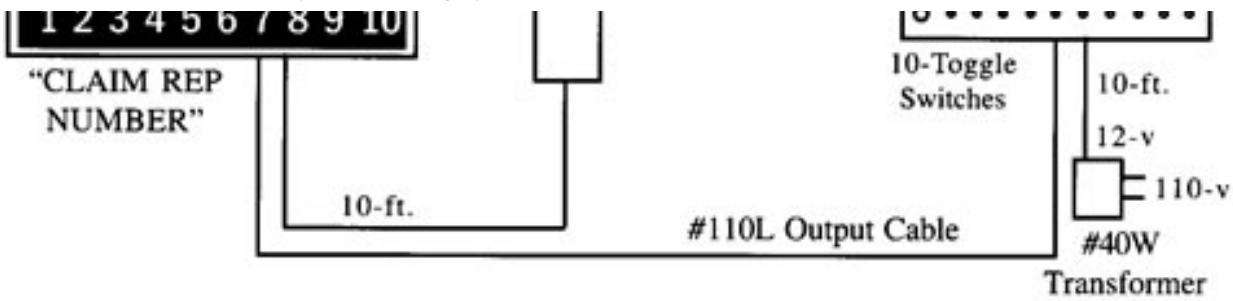

INTERVIEW WAITING & CLAIM REP CALLING SYSTEM - IWC-10 OPERATION:

Receptionist switches on number of claimants waiting, from 1 to 5. Claim Rep's light is "ON" when available for an interview. Claim Rep switches off light when meeting claimant at reception area.

INTERVIEW WAITING & CLAIM REP CALLING SYSTEM:

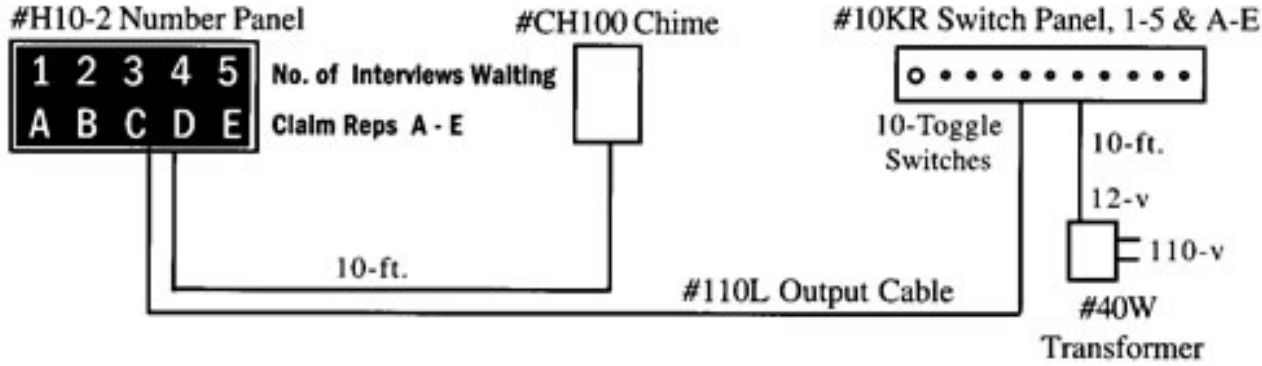

APPOINTMENT NOTIFICATION SYSTEM - APP-20 OPERATION:

Receptionist signals Claim Rep by number when a claimant has arrived for appointment, the white indicator light on #1CP-1 turns on at Claim Rep's cubicle, & CR's number lights up on #H20 Number Panel on wall. Claim Rep switches off all lights at cubicle when going to meet claimant at reception area.

APPOINTMENT NOTIFICATION SYSTEM:

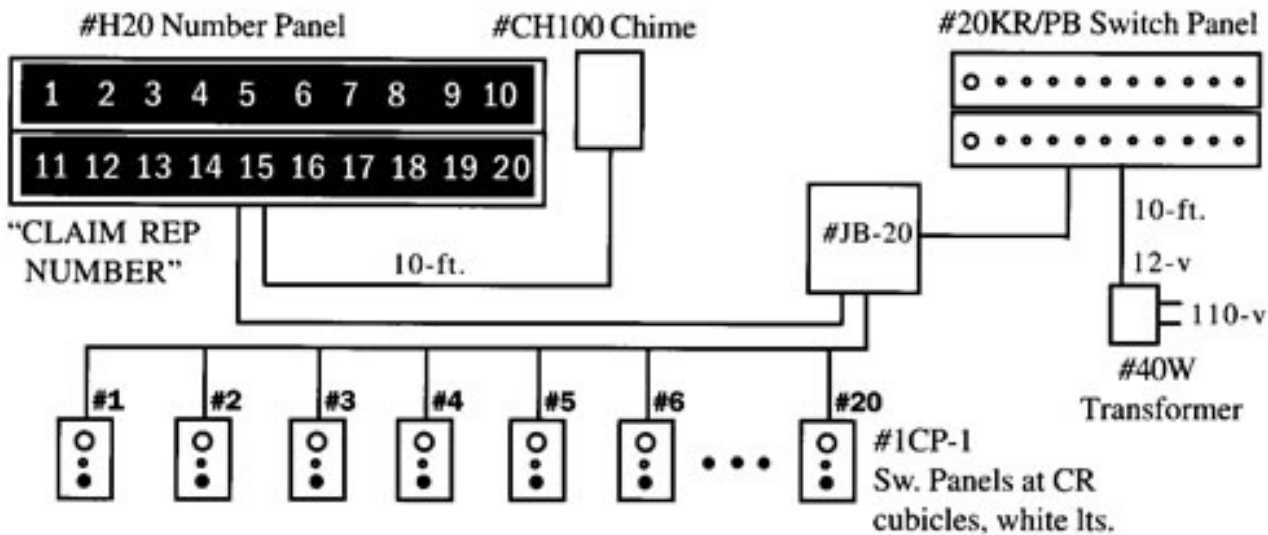

AVAILABILITY NOTIFICATION SYSTEM:

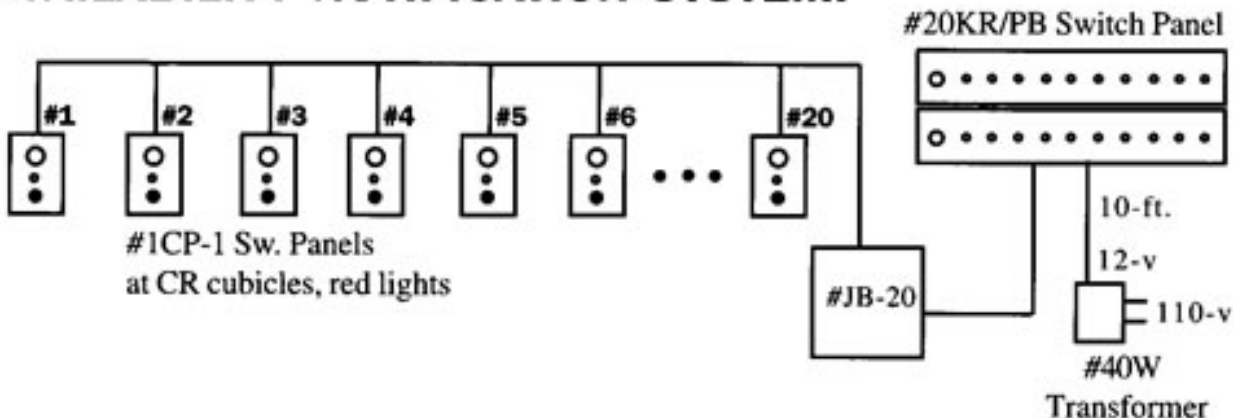

**AVAILABILITY
NOTIFICATION
SYSTEM - AVA-
20
OPERATION:**

To be used in conjunction with the Appointment Notification System above, or as a stand alone system. Light "ON" indicates Claim Rep is available for an appointment. Claim Rep switches off light at reception area when going to meet claimant.

MODEL - DESCRIPTION

CRI -10 Claim Rep Interview Calling System, 10-sta. 10KR Sw. Panel, H10 No. Panel 1-10, 60-ft. Cable, Chime, 40W Transformer. **\$1340.**

IWC-10 - Interview Waiting & Claim Rep Calling System, 10KR Sw. Panel, H10-2 No. Panel numbered 1-5 & A-E, 60-ft. Cable, Chime, 40W Transformer. **\$1340.**

APP-20 - Appointment Notification System, 20-station, 20KR/PB Sw Panel, H20 No. Panel 1-20, 20 1CP-1 Sw. Panels, 20-ft. E-Cable to JB-20, 30-ft. 110L Cable to H20, 200-ft. of Output Cable for the 1CP-1 Sw. Panels, Chime, 40W Transformer. **\$7520.**

AVA-20 - Availability Notification System, 20-station, 20KR/PB Sw. Panel, 20 1CP-1 Sw. Panels, 20-ft. E-Cable to JB-20, 200-ft. of Output Cable for the 1CP-1 Sw. Panels, Chime, 40W Transformer. **\$2340.**